

SUGIURA LAB.

[Signal Processing and Networking Technologies]

Center for Socio-Global Informatics

Wireless Communication Networks

Department of Information and Communication Engineering

Graduate School of Information Science and Technology

<http://sgurlab.iis.u-tokyo.ac.jp>

Advanced Wireless Communication Networks

Our research group focuses our attention on exploring key technologies of next-generation wireless communication networks, such as 5G and IoT. More specifically, our research interests include, but are not limited to: transmission technology, digital signal processing, network protocols, information theoretic security, cooperative communications, and wireless sensor networks.

Faster-than-Nyquist Signaling

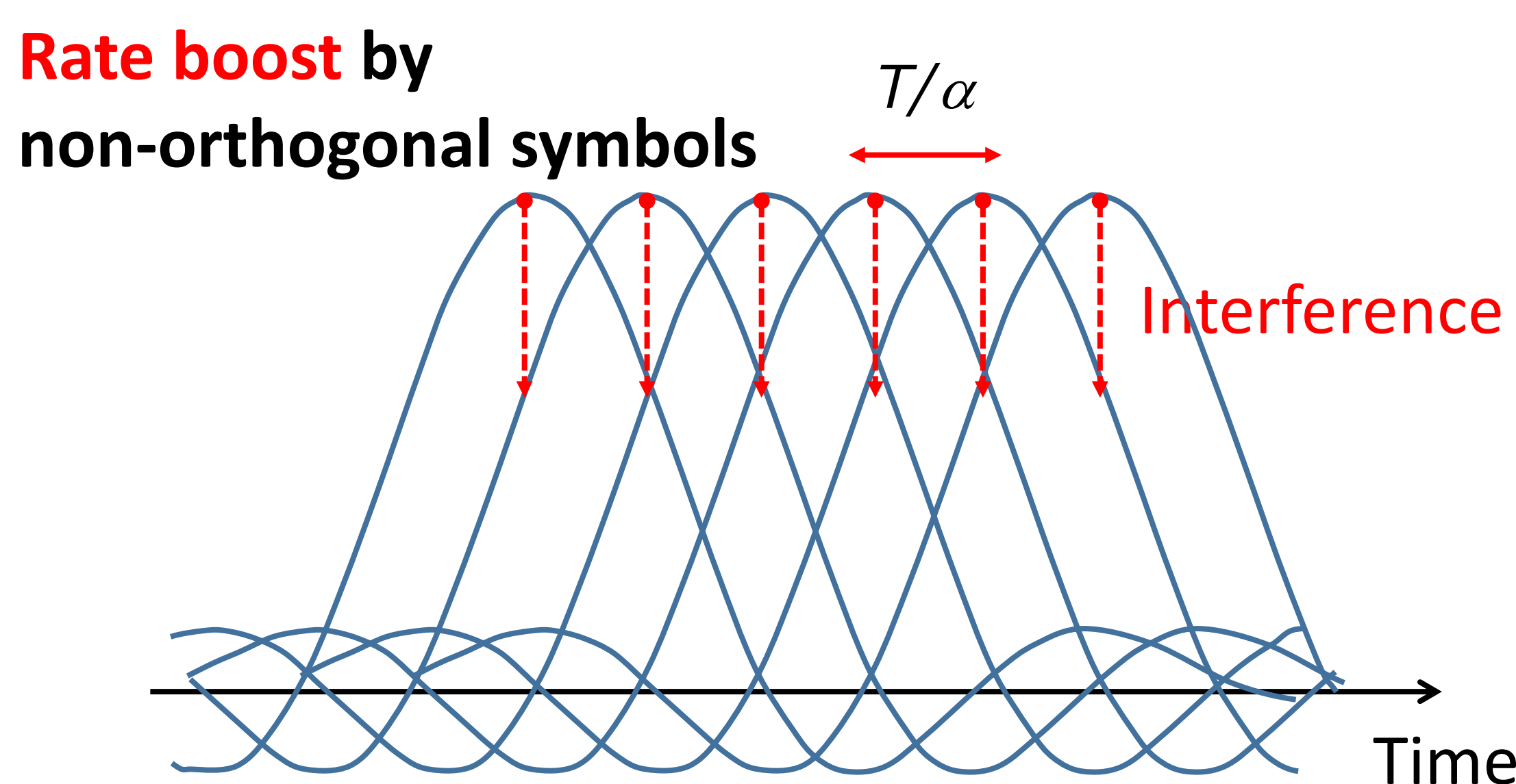

T : Nyquist symbol separation
 α : packing ratio

High Capacity

This scheme packs more symbols than those limited by the Nyquist criterion, hence increasing a transmission rate without imposing the bandwidth and power expansion.

Massive MIMO Transmissions

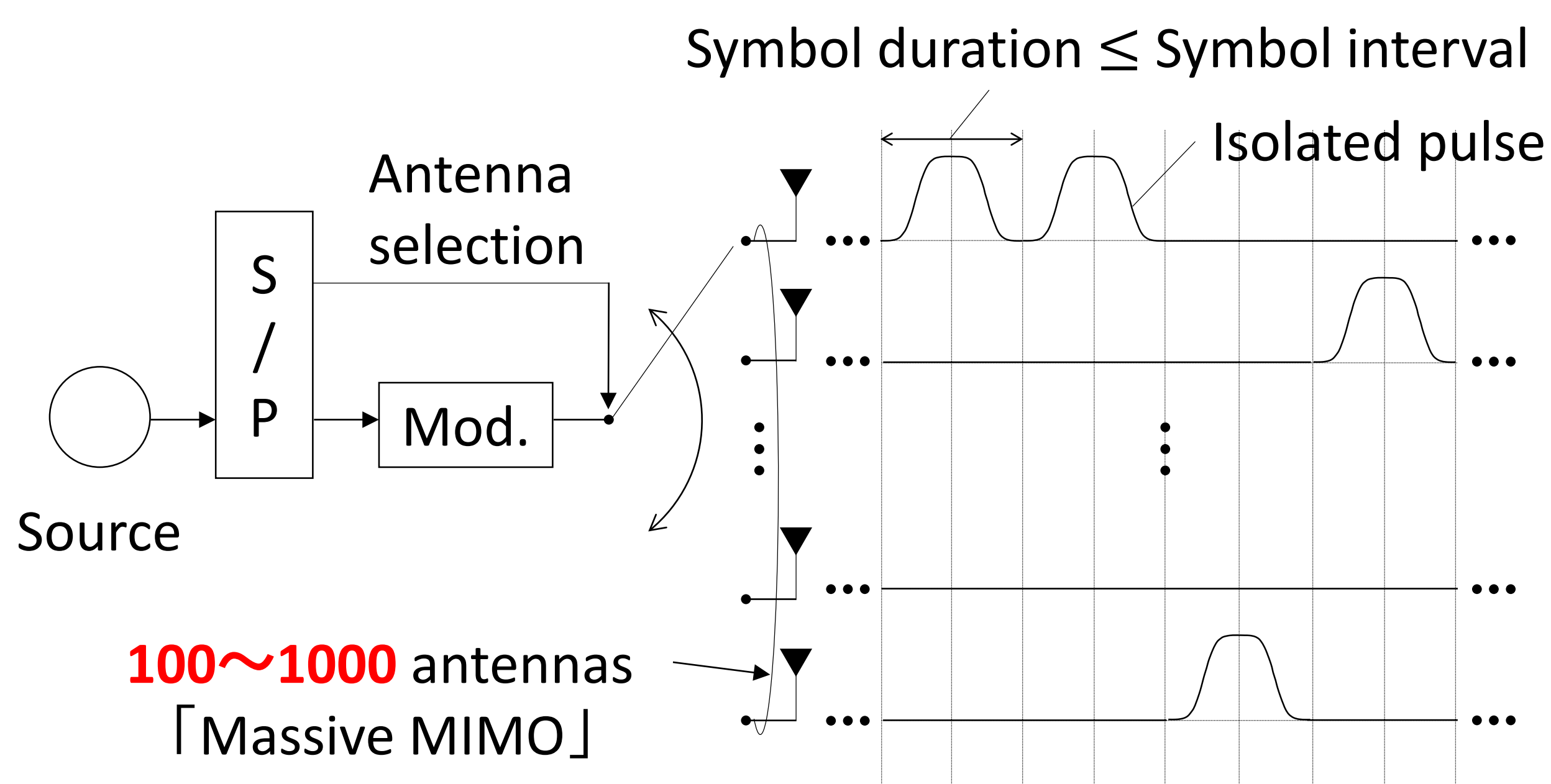

High Rate & High Energy Efficiency

Source bits are allocated onto large-scale antenna elements. This scheme operates in a single-RF transmitter structure, hence attaining high capacity and energy efficiency.

Physical Layer Security

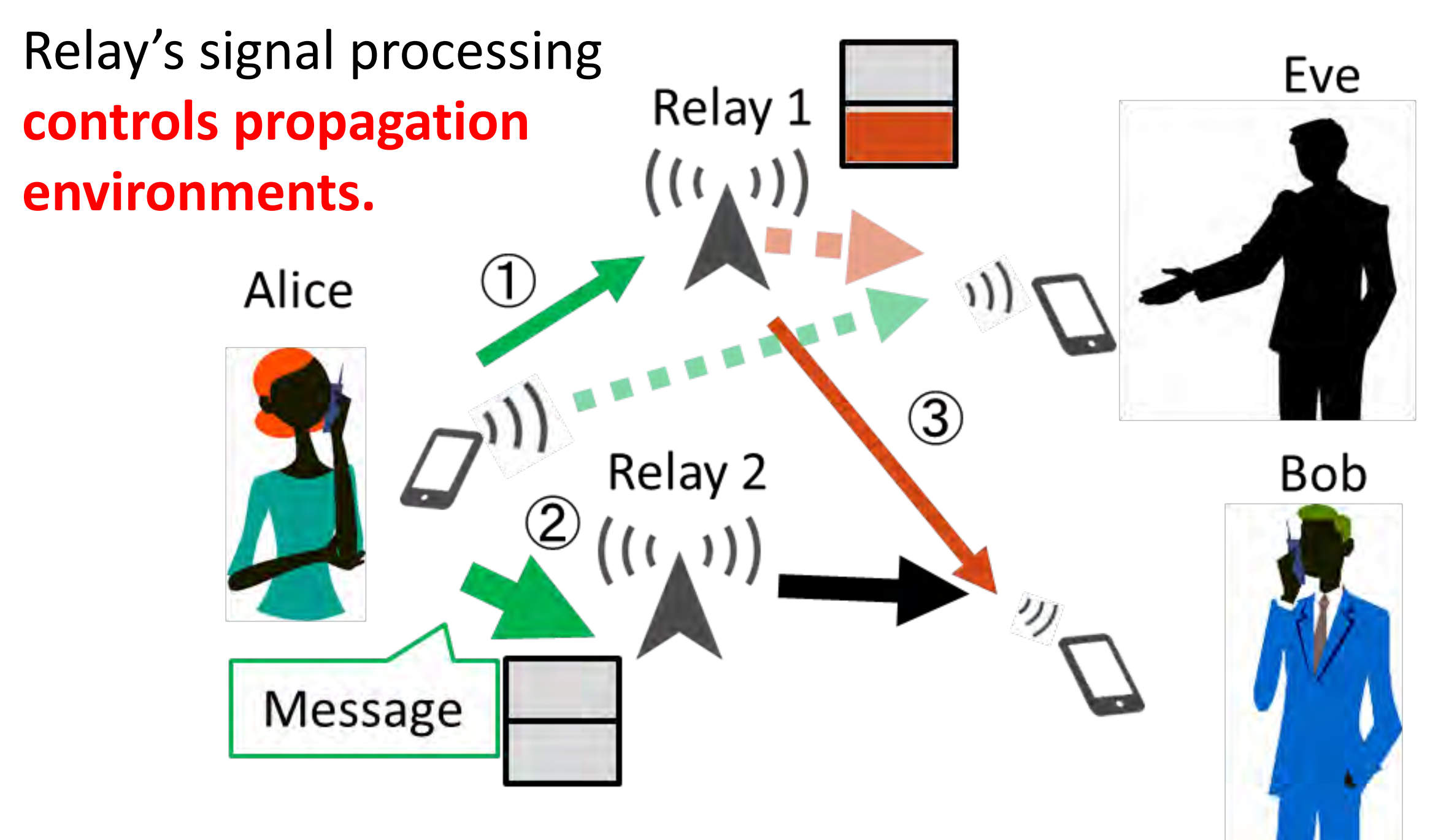

High Security

Physical layer security has the potential of attaining information-theoretically secure communications, without relying on encryption. This may be suitable for IoT networks.

Delay Tolerant Networks

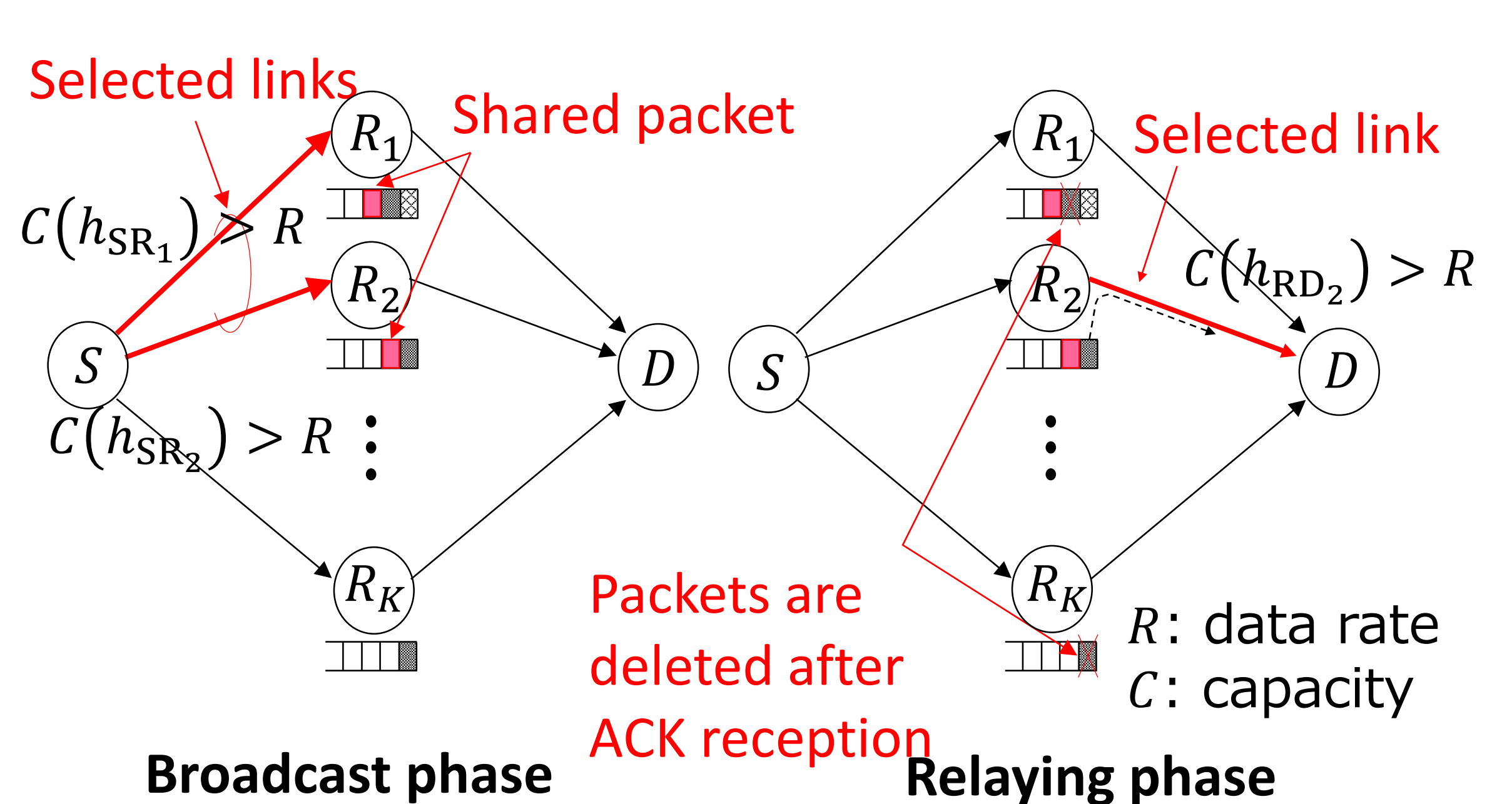

High Reliability

Exploiting data buffers at relay nodes in cooperative communications allow us to attain an improved reliability, owing to the explicit benefits of flexible link selection.