

Central Workshop

[Custom Design and Fabrication of Experimental Equipments, Parts and Samples]

Utility Department

Machine work , Glass work



<https://shisaku.iis.u-tokyo.ac.jp/en/>

Supporting Research with Manufacturing

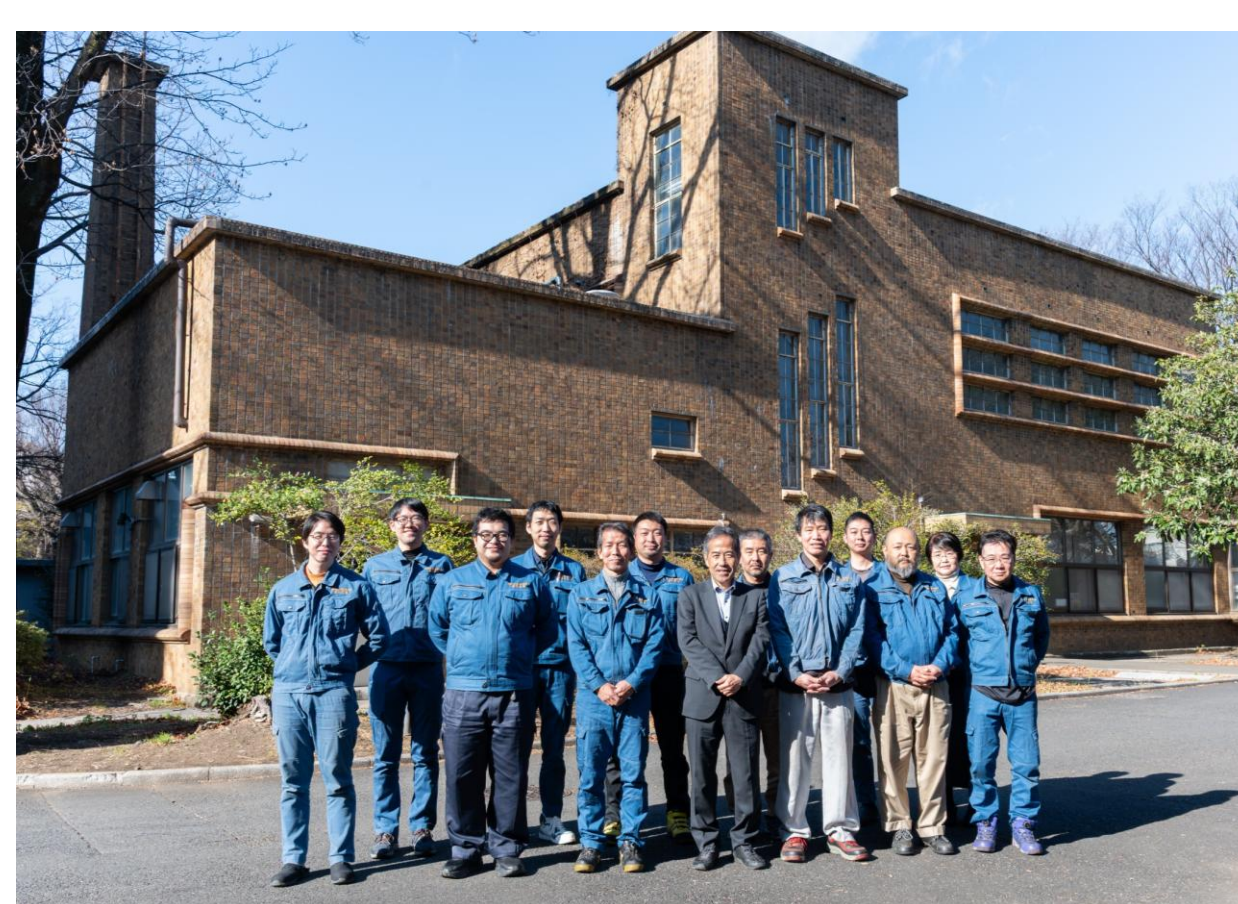

At the Central Workshop, professional engineers with various specialized skills and knowledge are designing and manufacturing experimental equipments, parts and test samples using advanced machine tools such as machining centers, turning centers, and electric discharge machines, etc.

In order to meet the requirements and qualities for research purposes, we work closely with researchers and students to support them with advanced technology and knowledge, from feasibility screening to services after delivery.

We welcome anybody who needs consultation on processing technologies and will be able to handle various material products, e.g. metals, non-ferrous metals, glass, resins, woods, etc.

In addition to manufacturing, we also offer technical training programs for students and faculty members. Please feel free to contact us.



Glass Shop

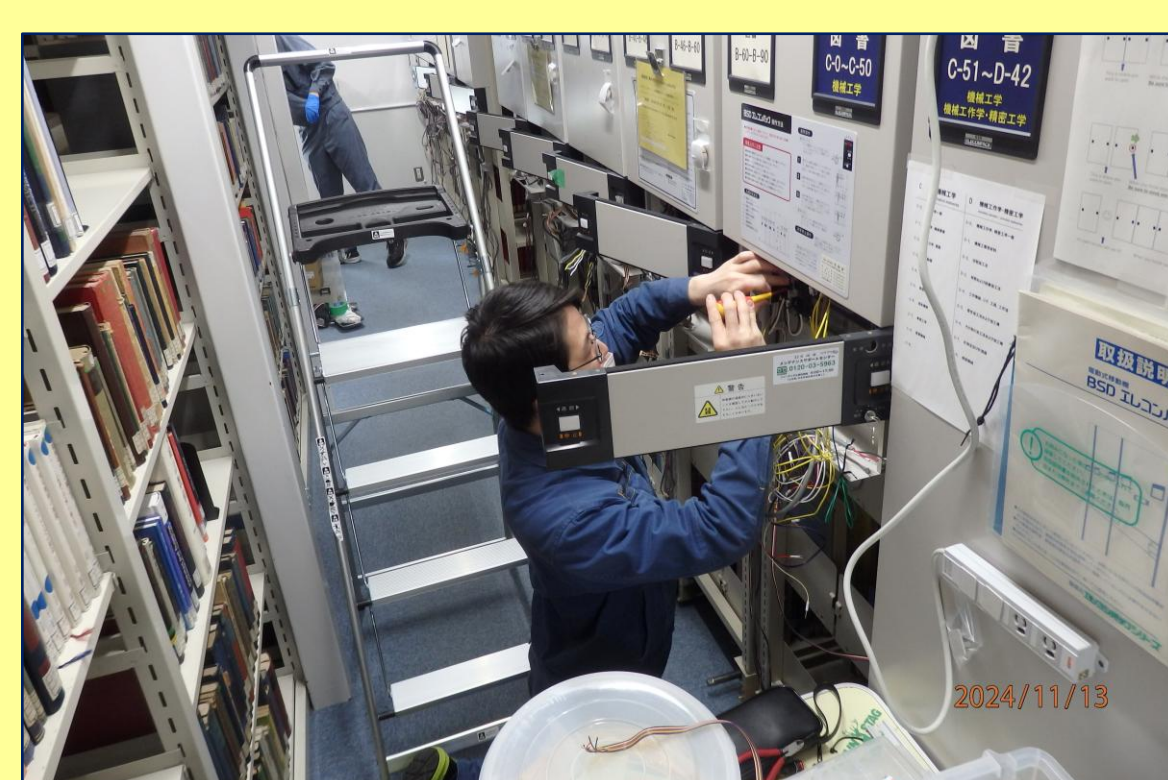

Turning Center



3D Printer



Machining Center

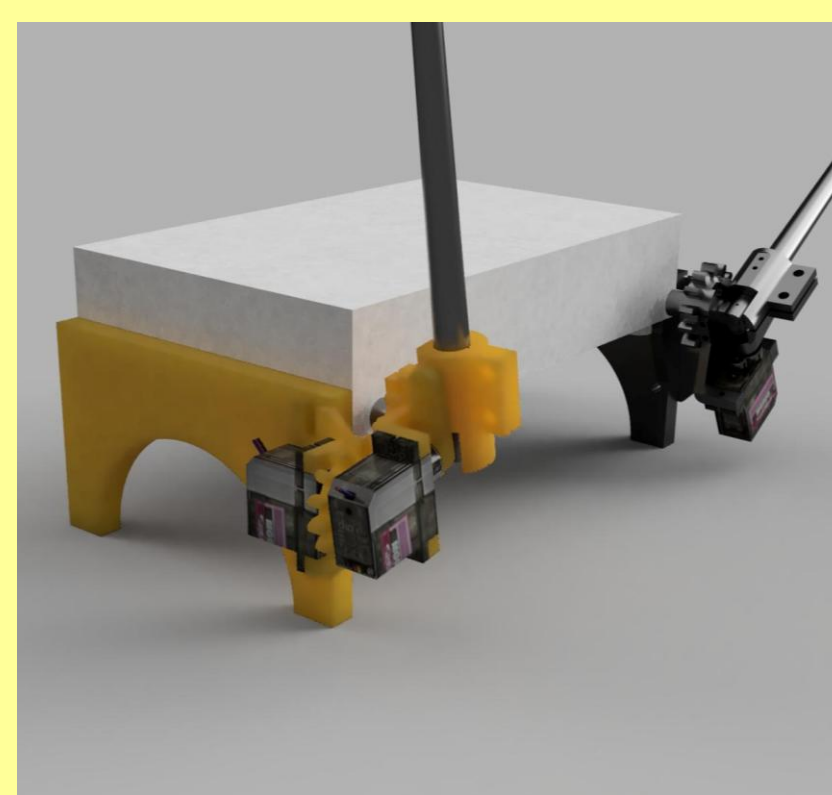

User workroom



Coordinate Measuring Machine



Wire Electric Discharge Machine

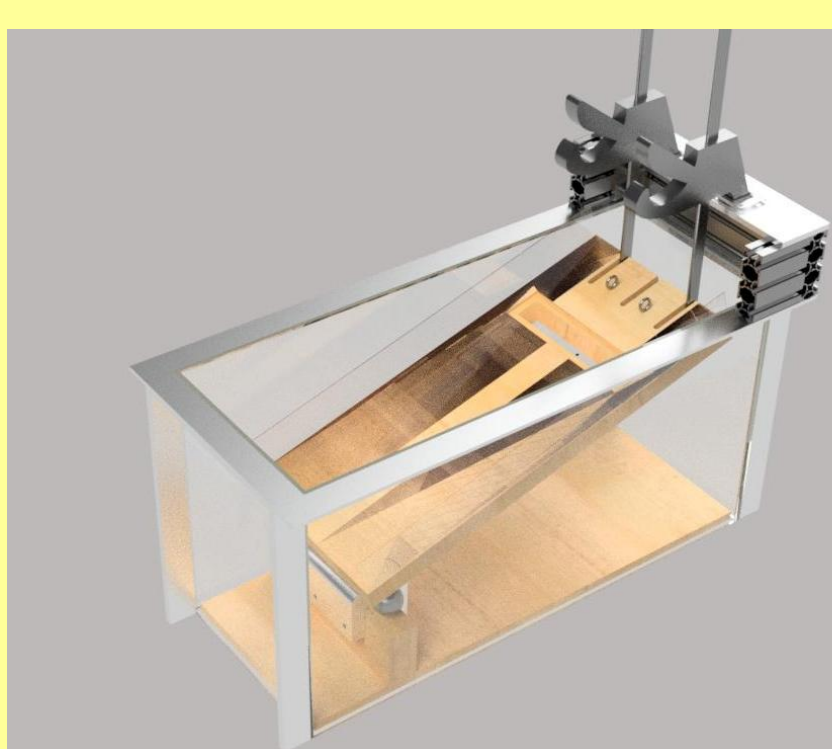

Machining technology room

Main mechanical equipments: turning center, machining center, wire electric discharge machine, milling machine, ordinary lathe, three-dimensional measuring machine, surface grinder, Tig welding machine and others, glass lathe, etc.