

TOKUMOTO LAB.

[Dislocations in topological insulators]

Department of Materials and Environmental Science

Nanostructure Materials Science

Department of Materials Engineering

<http://www.tokumoto.iis.u-tokyo.ac.jp>

◆ Topological insulator

Topological insulators are quantum materials that have a bulk band gap as an ordinary insulator but have protected metallic conducting states on their edge/surface. Topological insulators were first predicted in 2005, and have been experimentally verified in 2007.

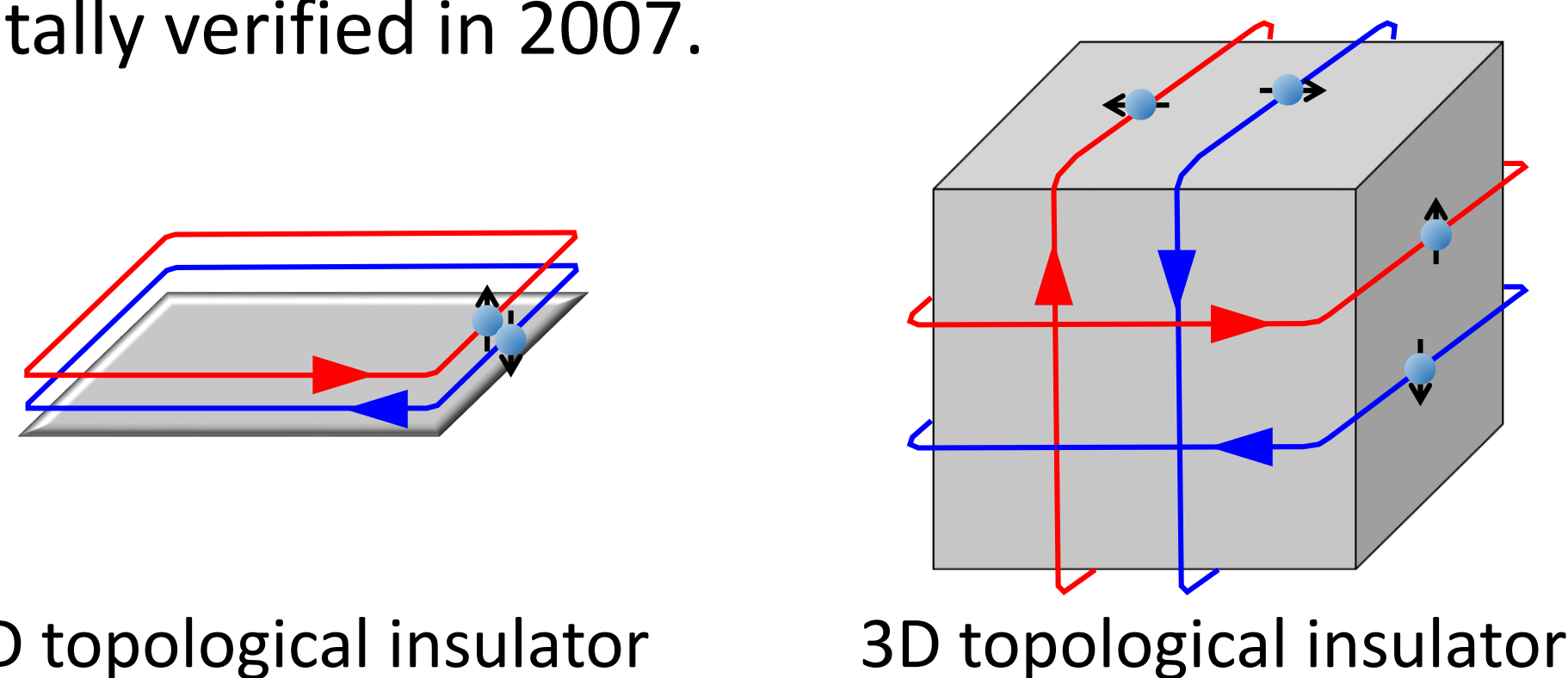

2D topological insulator

3D topological insulator

Metallic edge/surface states

- helically spin-polarized
- massless Dirac fermions
- robust against nonmagnetic disorder

◆ Dislocations in topological insulator

In 2009, it has been theoretically predicted that the metallic states also occur along dislocations in 3D topological insulators.

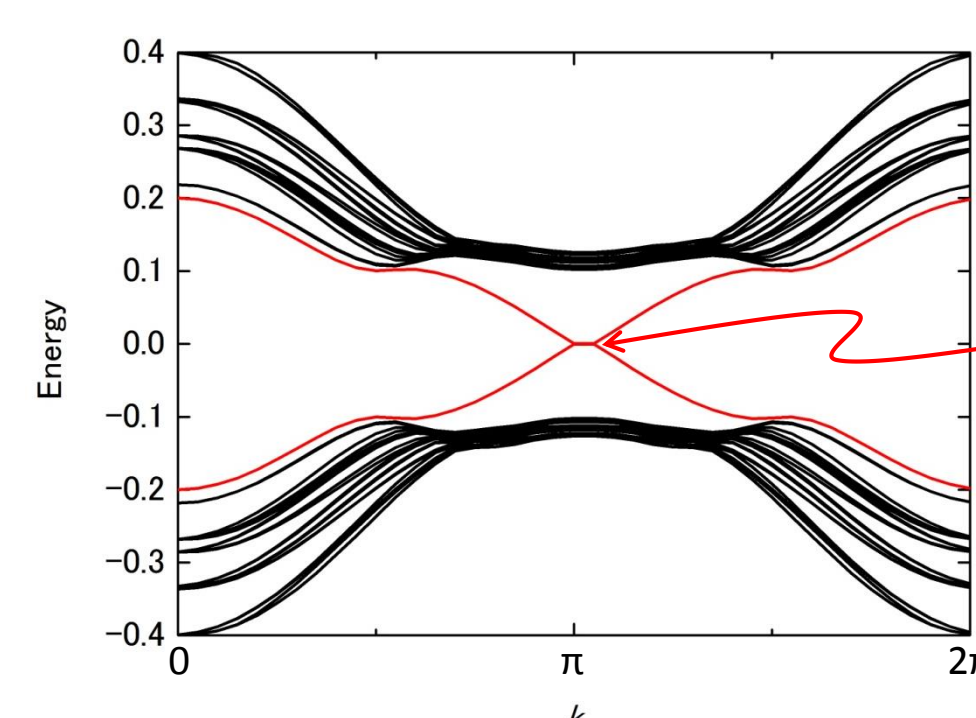
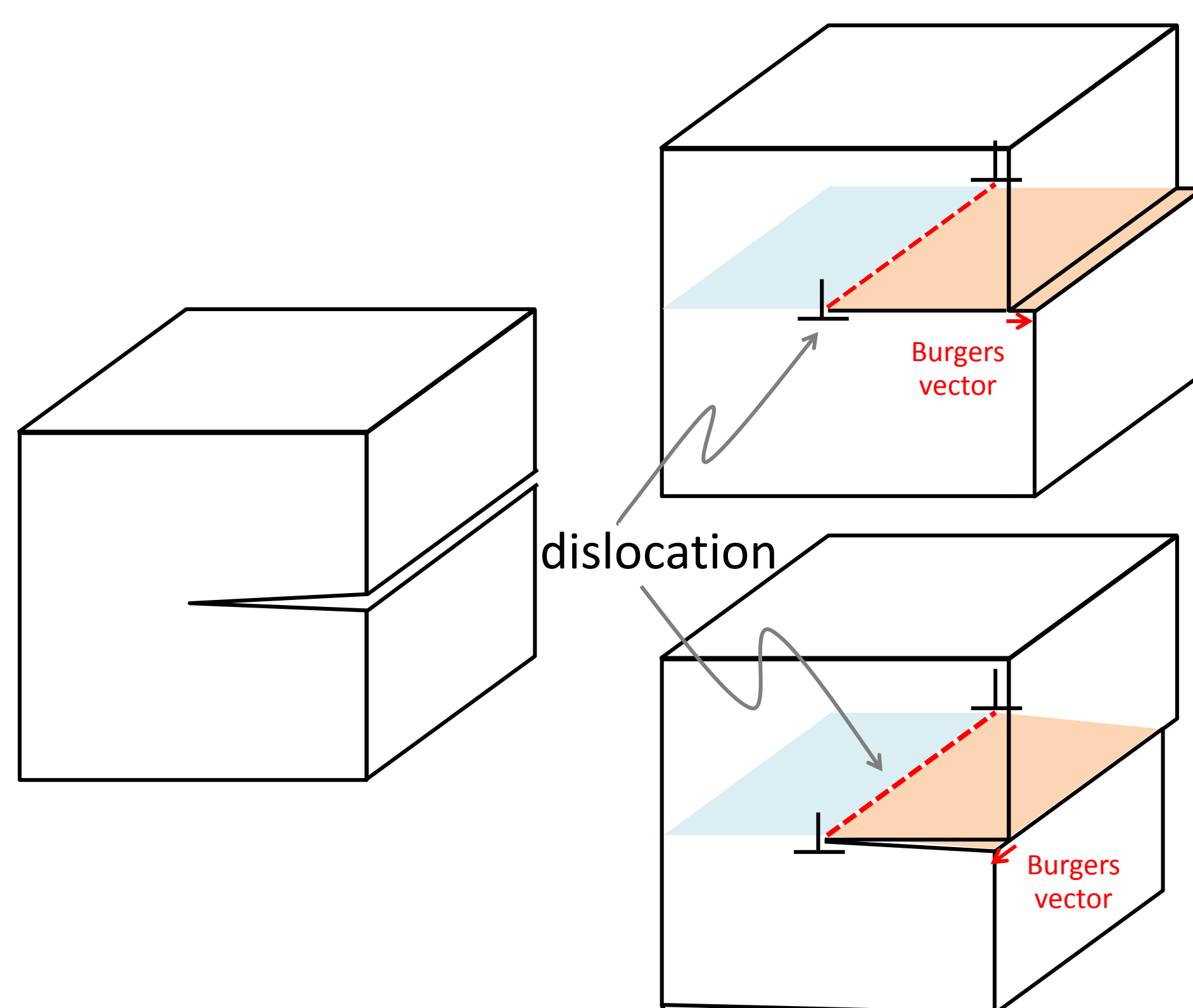

Metallic states localized along dislocations in topological insulators

◆ Experimental verification of dislocation conduction in topological insulators

We are trying to reveal and evaluate the metallic states of dislocations in topological insulators by microscopic evaluation of electrical properties.

Recently, we reported on “dislocation conduction in Bi-Sb topological insulators”.

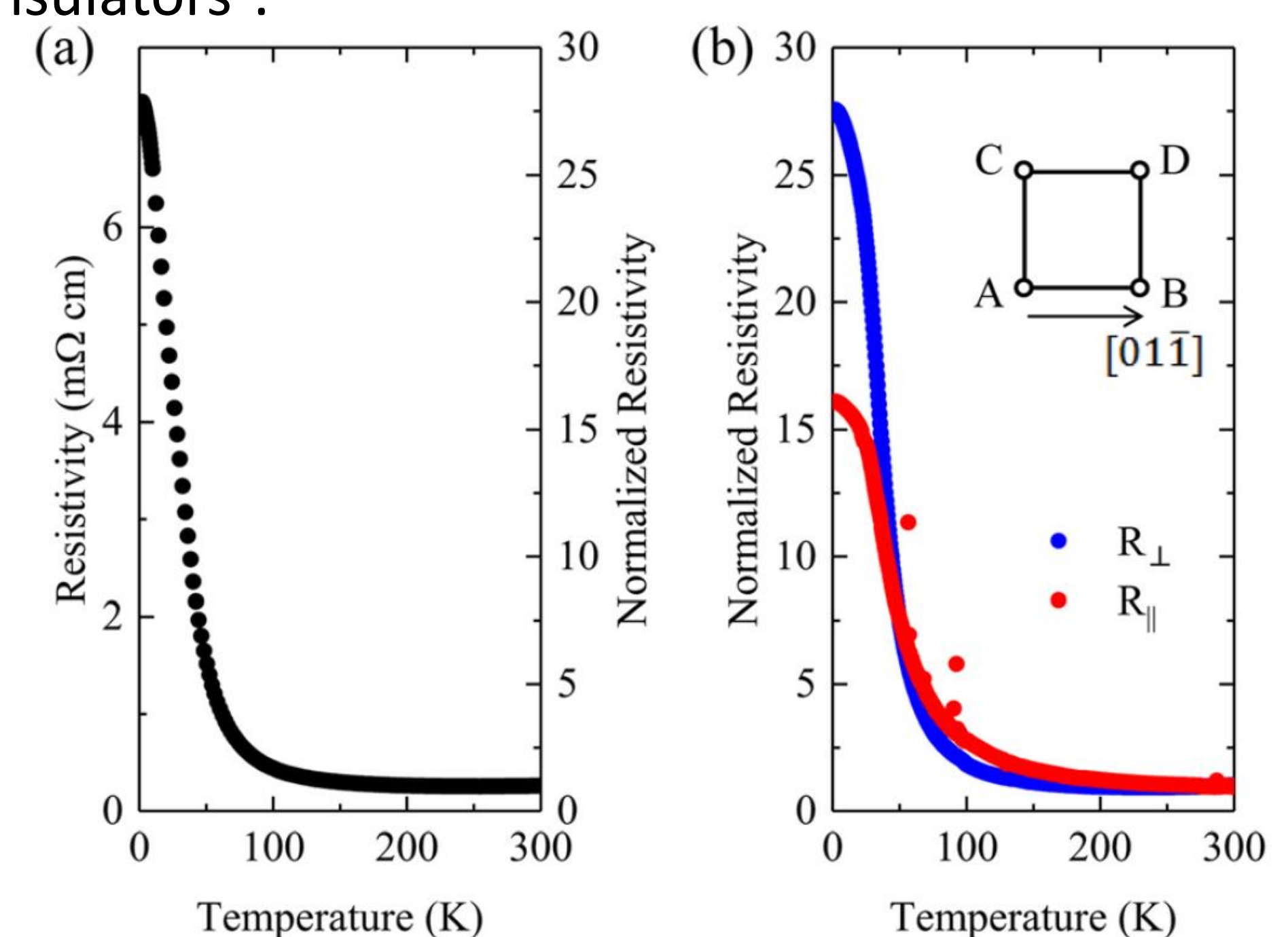
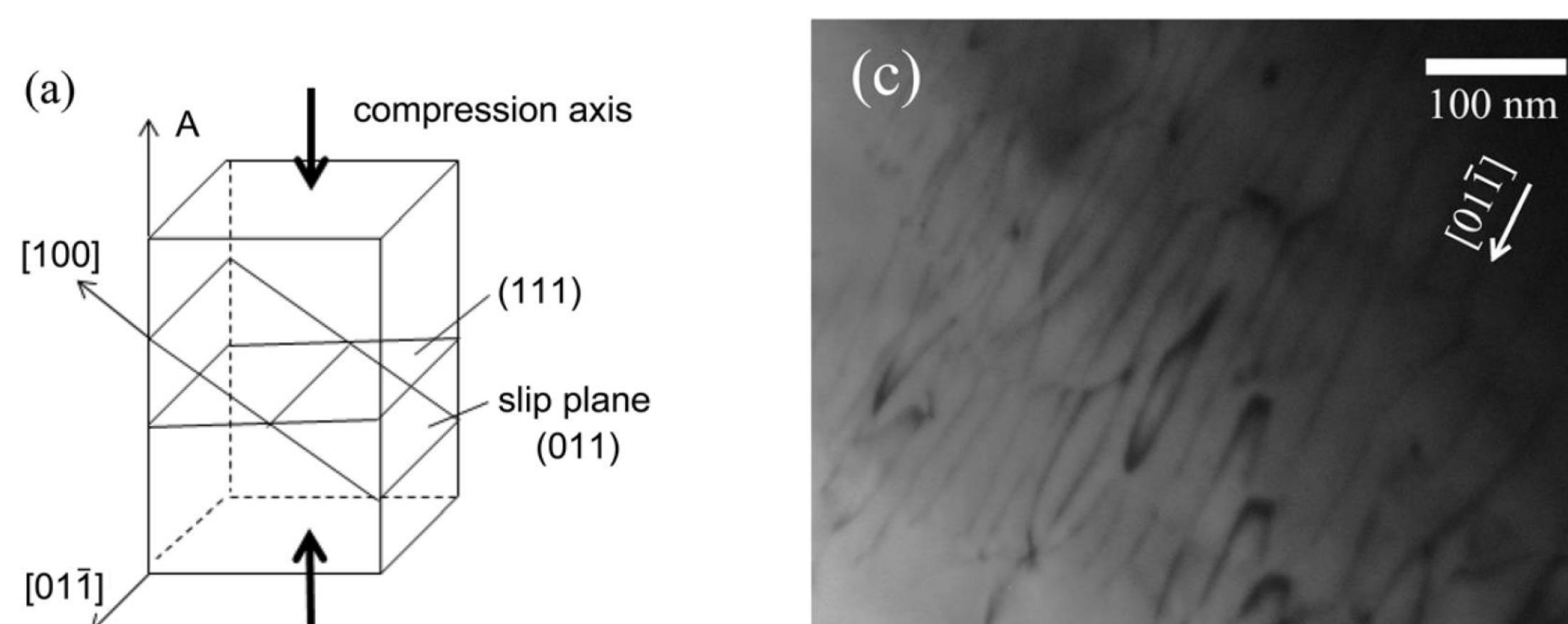

H. Hamasaki *et al.*, *Appl. Phys. Lett.*, **110** (2017) 092105 1-4.